

議程 ➤ **管內液體流量量測方法**

內容 ➤ **超音波流量計原理及用途介紹**

Flexim GmbH
德國弗萊克森公司
台灣區代表 王智德

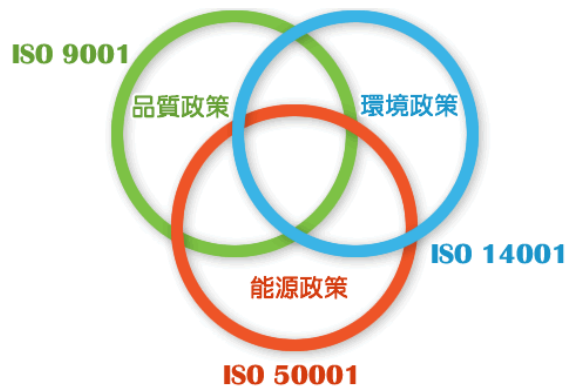

鍋爐、
空調、
電力、
空壓

空調系統冰水主機能源效率標準

執行階段		第二階段		
實施日期		民國九十四年一月一日		
型 式	冷卻能力等級	能源效率比值 (EER) kcal/h-W	性能係數 (COP)	
水冷式	容積式 壓縮機	<150RT	3.83	4.45
		≥150RT ≤500RT	4.21	4.90
		>500RT	4.73	5.50
	離心式 壓縮機	<150RT	4.30	5.00
		≥150RT <300RT	4.77	5.55
		≥300RT	5.25	6.10
氣冷式	全機種	2.40	2.79	

資料來源: 經濟部能源局

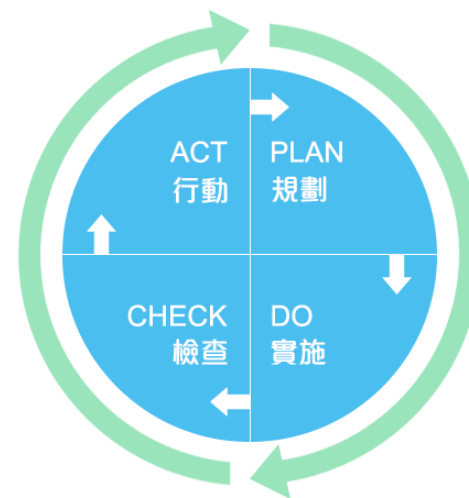
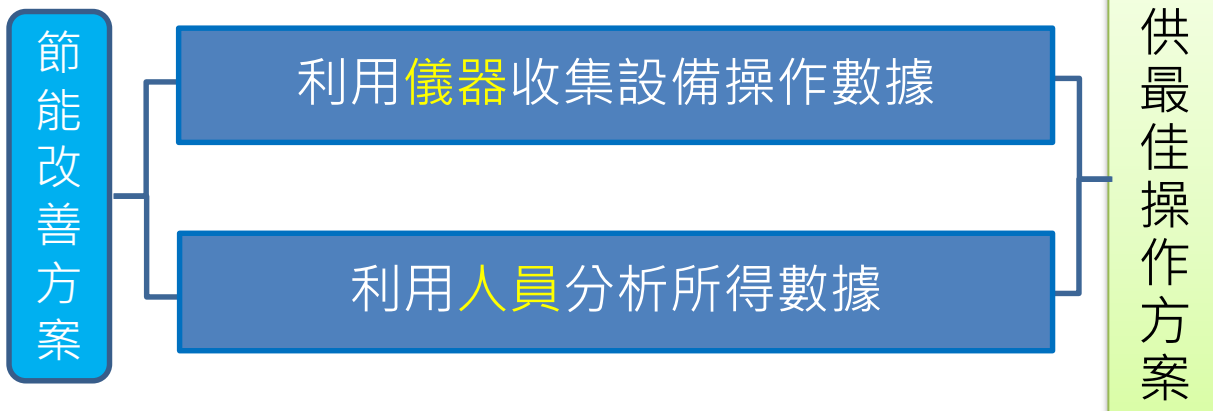

1

管內液體流量量測方法

2

流量計原理

3

超音波流量計用途介紹

4

超音波流量計的操作使用

工業上常見的流量計

Electronical
電子技術

Clamp-on Ultrasonic
夾管式超音波流量計



Ultrasonic
超音波流量計



Electromagnetic
電磁流量計



Insertion thermal mass
(插入式)熱質量流量計



Vortex
渦階流量計



Coriolis
科氏力(質量)流量計



Variable Area
(變化)面積式流量計



Differential Pressure
差壓流量計



Positive Displacement
(正位)活塞式流量計



orifice plate
流孔板流量計



Oval gear meter
橢圓齒輪式流量計



V-cone flowmeter
V錐流量計



Turbine
渦輪流量計



Mechanical
機械技術

Price low

Price high

1

管內液體流量量測方法

2

流量計原理

3

超音波流量計用途介紹

4

超音波流量計的操作使用

壓力式 (Pressure-based meters)

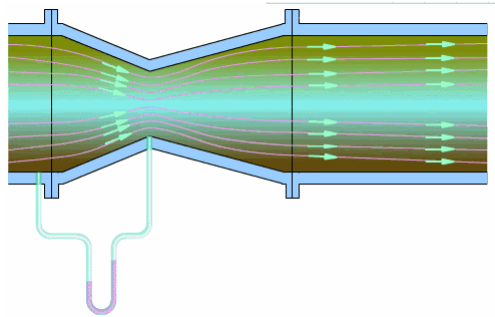

文氏管 (Venturi meter)

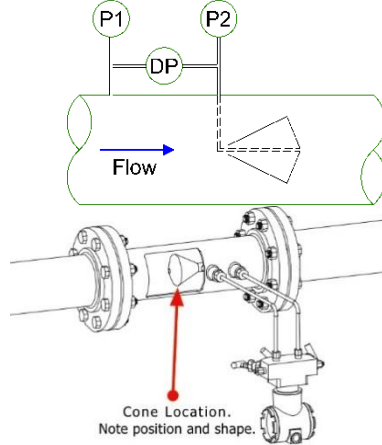

錐型體 (Cone meters)

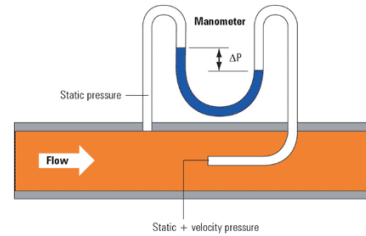

皮頭管 (Pitot-tube)

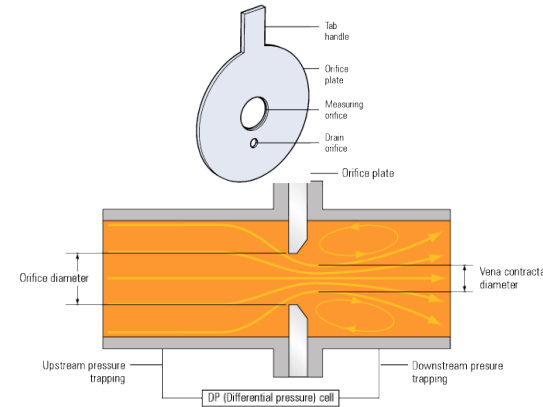

流孔板 (Orifice plate)

優點	<ul style="list-style-type: none"> · 價格門檻低
缺點	<ul style="list-style-type: none"> · 量成比很低 (孔板: 4:1...5:1) · 保證精度常需常校正 · 壓損高 · 對異物非常敏感(堵塞、磨耗) · 需定期檢修、清潔

機械式 (Mechanical flowmeters)

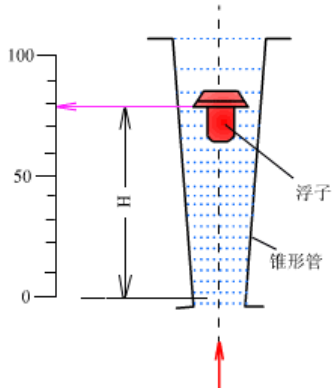

面積(變化)式流量計(Variable Area)

高→面積大→通過流量大
低→面積小→通過流量小

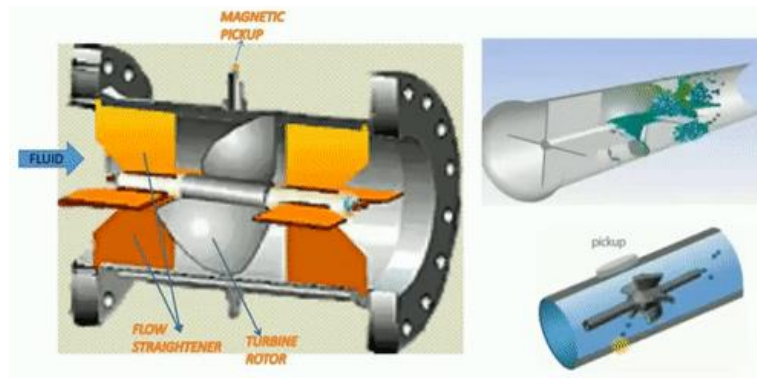

渦輪式 (Turbine flow meter)

轉速大→通過流量大
轉速小→通過流量小



橢圓齒輪式流量計(Oval gear meter)

轉速大→通過流量大
轉速小→通過流量小

優點

- 結構簡單，價格低
- 適小流應用
- 壓損不大

缺點

- 量成比很低 (10:1)
- 精度不高
- 對異物敏感(堵塞)
- 含油汙(氣體)不適用

優點

- 精度高 (精密渦輪)
- 價格低 (簡易渦輪)

缺點

- 保證精度常需常校正
- 壓損大
- 對異物敏感
(加速磨耗、損壞,
例: 天然氣/水槌)
- 需定期檢修、更換部件

優點

- 準度很高 (0.1%)

缺點

- 量成比低 (10:1...70:1)
- 保證精度常需常校正
- 壓損很大
- 對異物敏感
(加速磨耗、損壞)
- 需定期檢修、更換部件

渦街式 (Vortex flow meters)

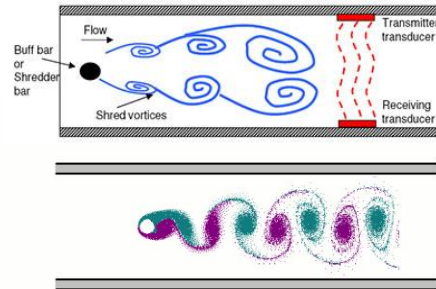
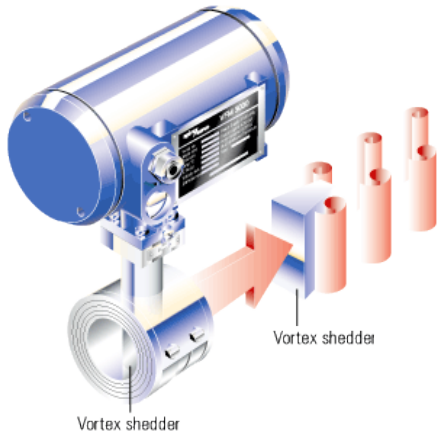

擺動頻率大 → 通過流量大
擺動頻率小 → 通過流量小

熱傳式 (Thermal mass flow meters)

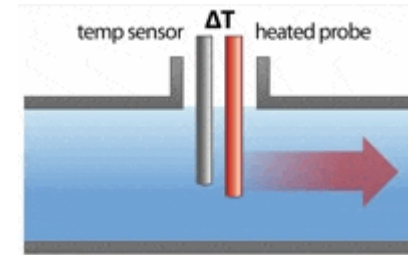

溫度差大 → 通過流量大
溫度差小 → 通過流量小

優點	<ul style="list-style-type: none"> • 價格不高 (小管徑or 插入型) • 部件簡單 • 測量液體、氣體 (少數可測蒸氣)
缺點	<ul style="list-style-type: none"> • 量成比低 (40:1) • 有一定壓損 • 水垢與陳積物會造成堵塞 • 不適用高黏度流體 • 對管路振動敏感

優點	<ul style="list-style-type: none"> • 價格便宜 • 能夠檢測氣體 • 壓損不大
缺點	<ul style="list-style-type: none"> • 量成比低 (10:1..100:1) • 影響精度因素多 <ul style="list-style-type: none"> * 流體溫度變化時易產生誤差 * 流體的熱傳特性(類型和成分) * 溫度感測器或加熱元件上有沉澱物/積垢時會產生誤差

電磁式 (Electromagnetic flow meters)

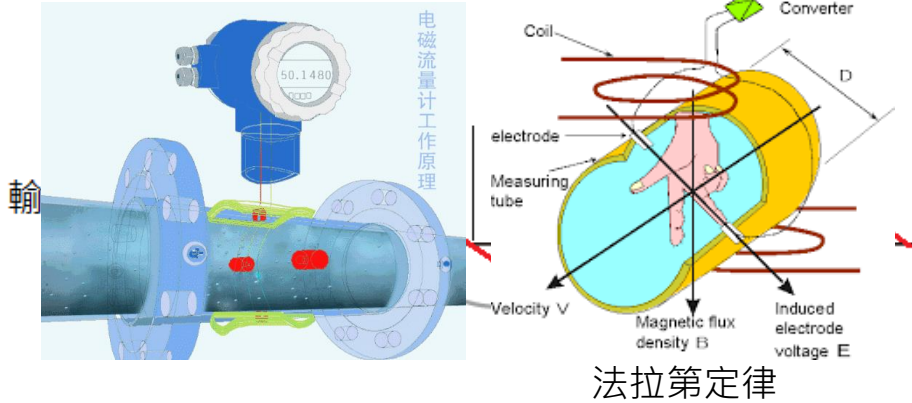

科氏力式 (Coriolis flow meters)

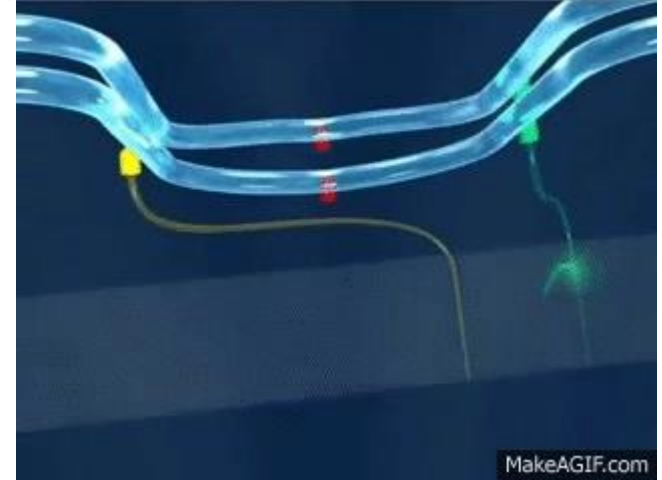

優點	<ul style="list-style-type: none"> · 精度高(~%0.5) · 能測量高濁度的液體 (例: 廢水, 多固體、氣泡) · 沒有壓損
缺點	<ul style="list-style-type: none"> · 不能測量不導電的流體 (例: 純水) · 安裝需要一段直管(穩流條件) · 一體式(帶短管), 停車安裝 · 固體含量高會減短使用壽命(內襯磨耗) · 價格隨管徑增加...大管徑很貴

優點	<ul style="list-style-type: none"> · 精度很高(~%0.1) · 能測量質量流量 (&密度) · 能測量高黏度液體 · 唯一安裝沒有直管段要求
缺點	<ul style="list-style-type: none"> · 價格貴(視精度) · 壓損很大 · 易受振動的影響 · 一體式(帶短管), 停車安裝

超音波 - 時差法流量計 (液體&氣體)



優點

- 精度(通道增加提高)
- 能量測熱能(BTU)
- 能量測濃度 (FLEXIM P10X[®] S)
- 能檢測高黏度液體
- 不受振動的影響
- 無壓損

缺點

- 多通道價格較高
- 高精度需要一段直管

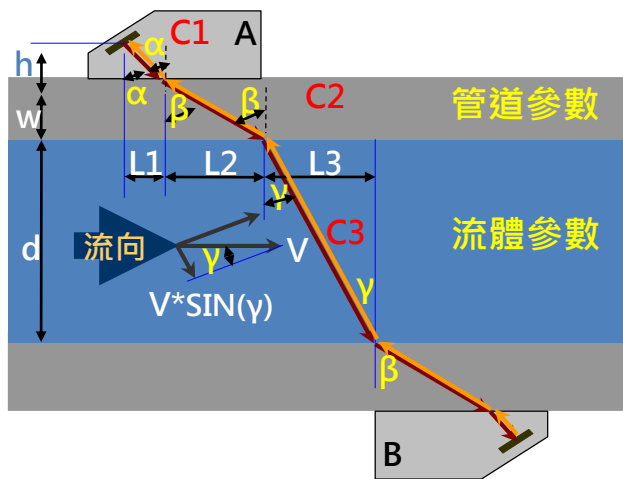

流體流速：

$$V = \frac{C_y^2 \cdot \Delta t}{2 \cdot L_3}$$

流體聲速：

$$C_y = \frac{\sqrt{d^2 + L_3^2}}{t_{avg} - 2(t_1 + t_2)}$$

流體流量：

$$Q = V \times A \quad Q = \frac{\pi \cdot C_y^2 \cdot \Delta t \cdot d^2}{8 \cdot L_3}$$

$$\text{順流速} = \text{聲速 } v_k + \text{流速} = \frac{\text{音程距離 } L_k}{\text{音程時間 } t_1} \dots (1)$$

$$\text{逆流速} = \text{聲速 } v_k - \text{流速} = \frac{\text{音程距離 } L_k}{\text{音程時間 } t_2} \dots (2)$$

$$\text{水流速} = \frac{(1) - (2)}{2} \quad \text{聲速} = \frac{(1) + (2)}{2}$$

超音波 - 都普勒流量計 (液體)

都普勒效應

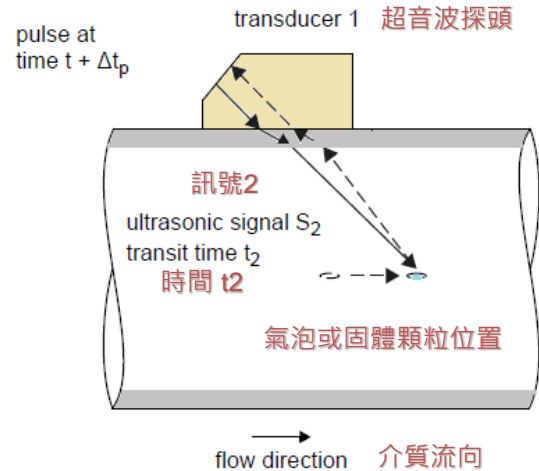
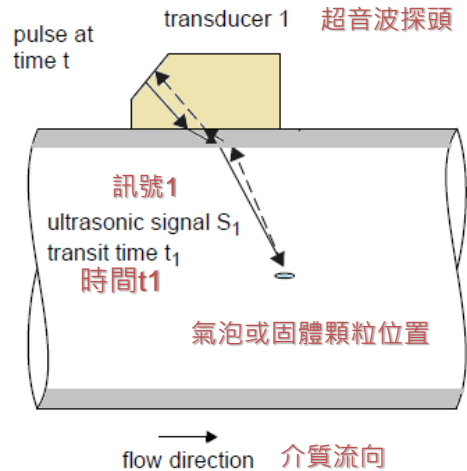
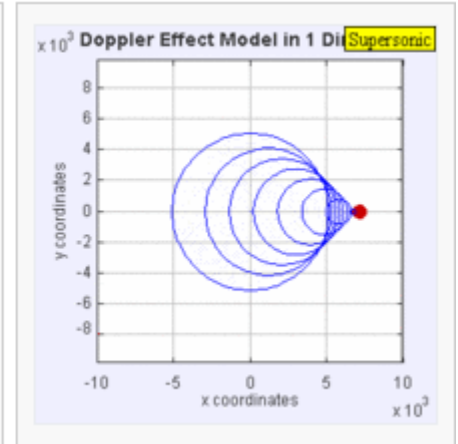
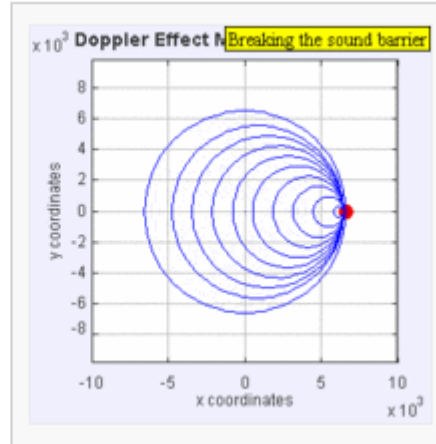
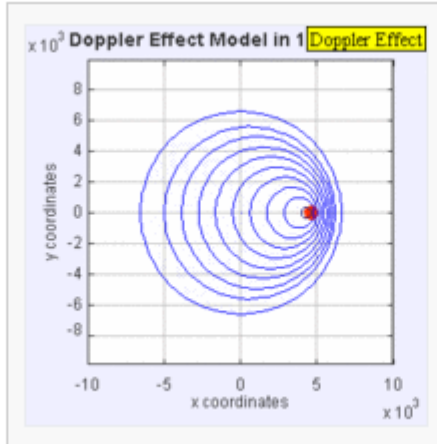
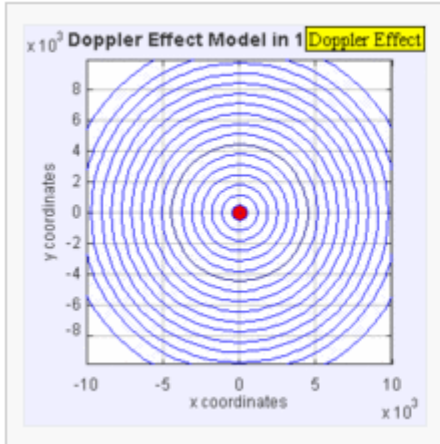

優點

- 價格較低
- 壓損=0
- 能檢測高固體顆粒/氣泡液體

缺點

- 精度差 ($>5\%$)
- 只適用液體
- 不適用無固體顆粒/氣泡液體
- 需要一段直管

流量計選擇重要考量點

漩渦流量計

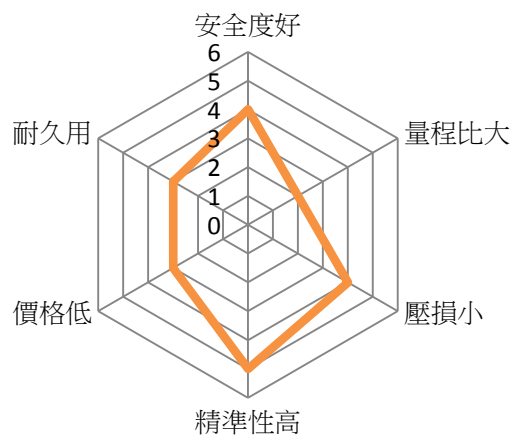

電磁流量計

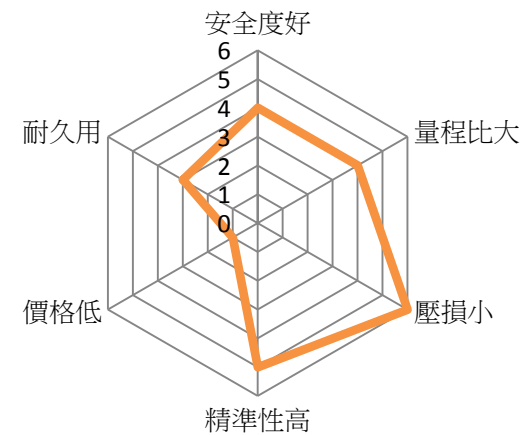

綠基會 外夾式超音波流量計 FLEXIM

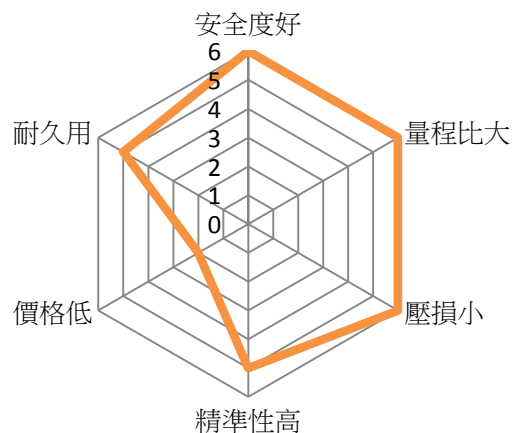

插入式超音波流量計

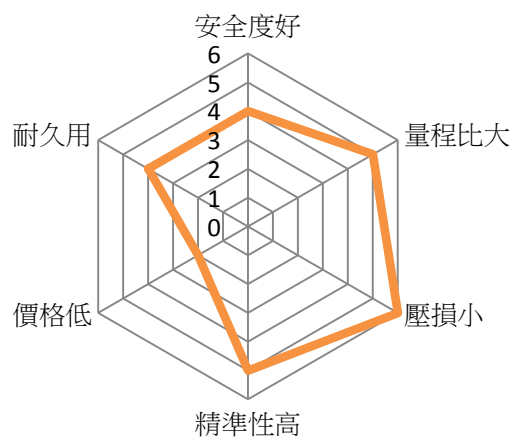

科氏力質量流量計

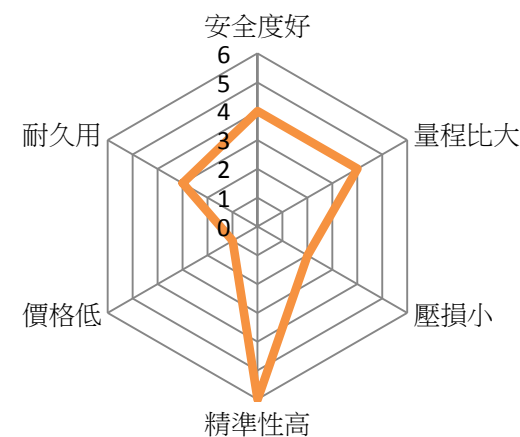

安全性

- 接觸件腐蝕
- 洩漏危險性
- 流體汙染



接觸件洩漏

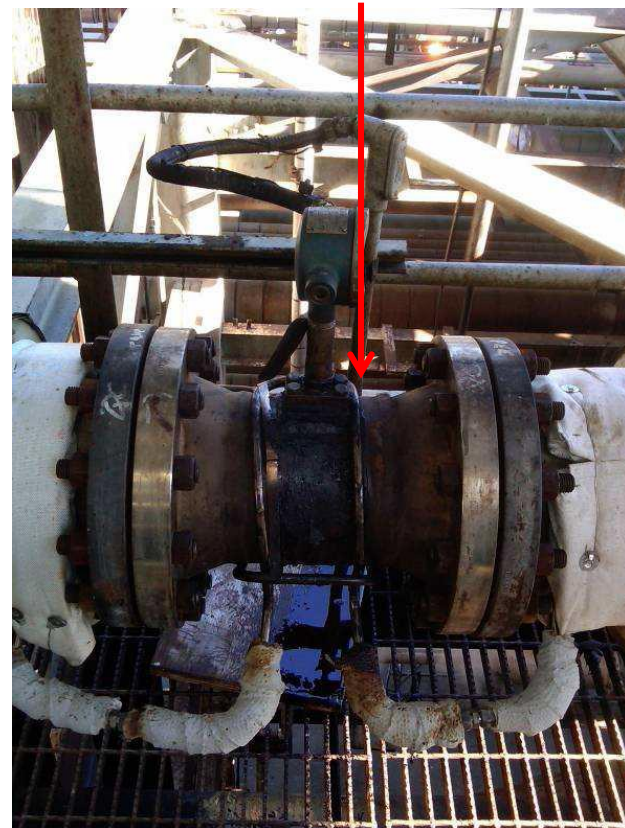

管外測量

- 不接觸
- 無洩漏危險
- 不流體汙染
- 不停車安裝
- 方便比對、校正



壓損 → 節能 (~ 採購 & 設計常忽略的議題)

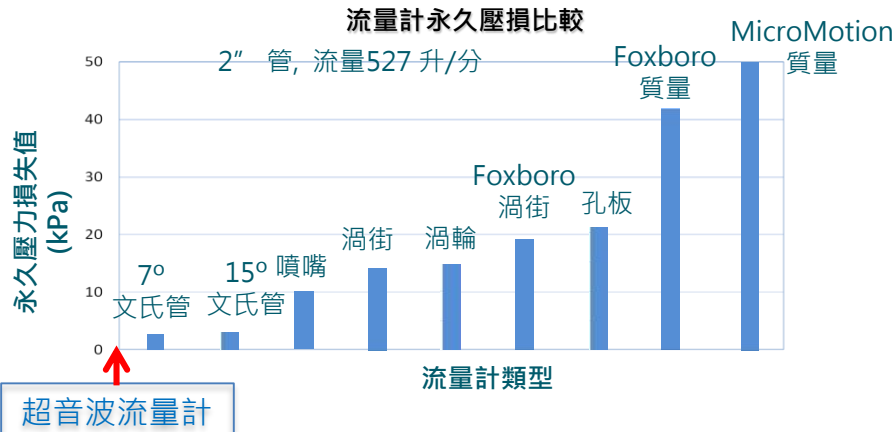

價格

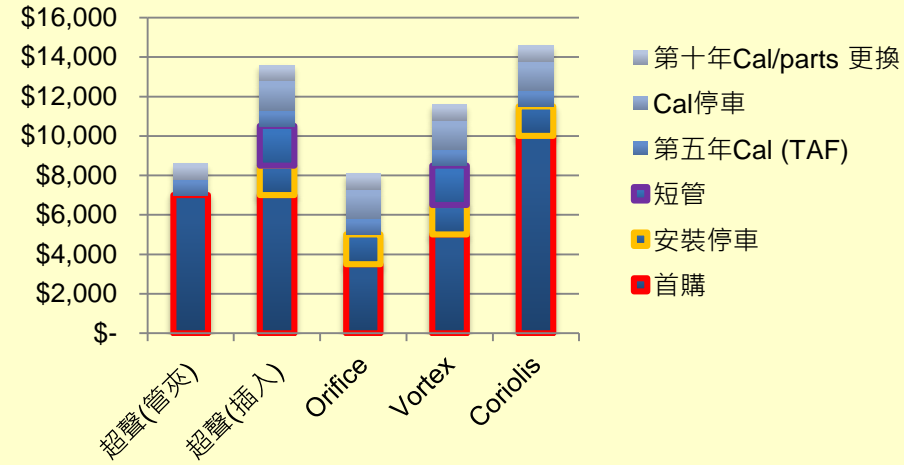

精確度 (超音波流量計)

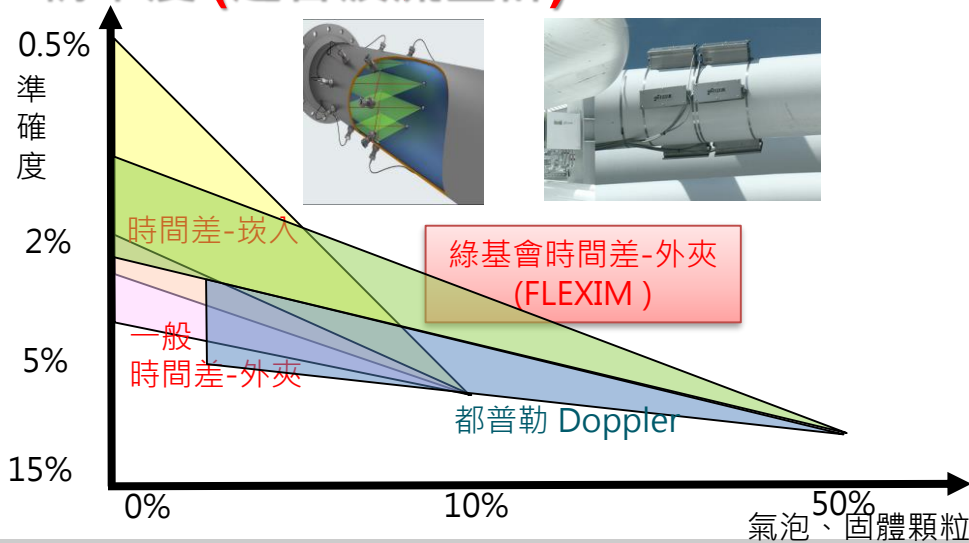

耐用性

- 主機: 防摔膠套
- 探頭: 鎧裝電纜
- 攜帶箱: PeliCase (多國軍規使用)



攜帶式超音波流量計的選擇建議

➤ 操作容易, 快速反應, 精準測量

◆ 操作容易

- 自動辨識探頭
- 安裝快速
- 一般情形5分鐘可完成一點測量 (無保溫)

◆ 精準測量

- 探頭有溫度補償 (內置RTD, 依據ASME MFC-5.1-2011)
- TAF 確認 (or 定期校正)

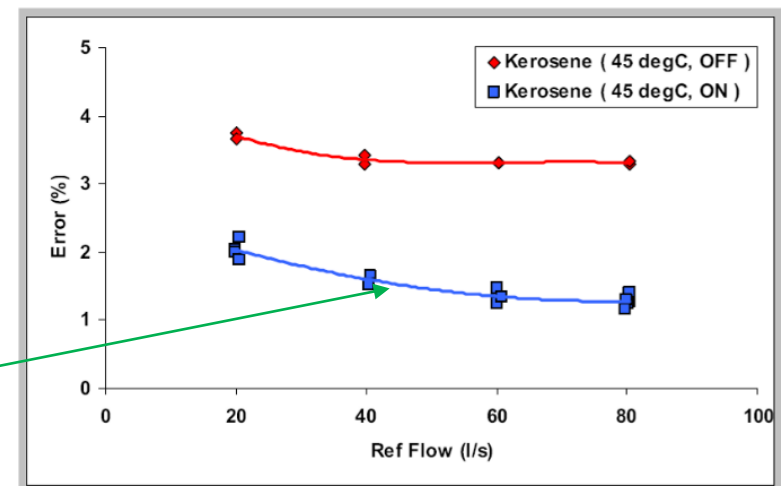
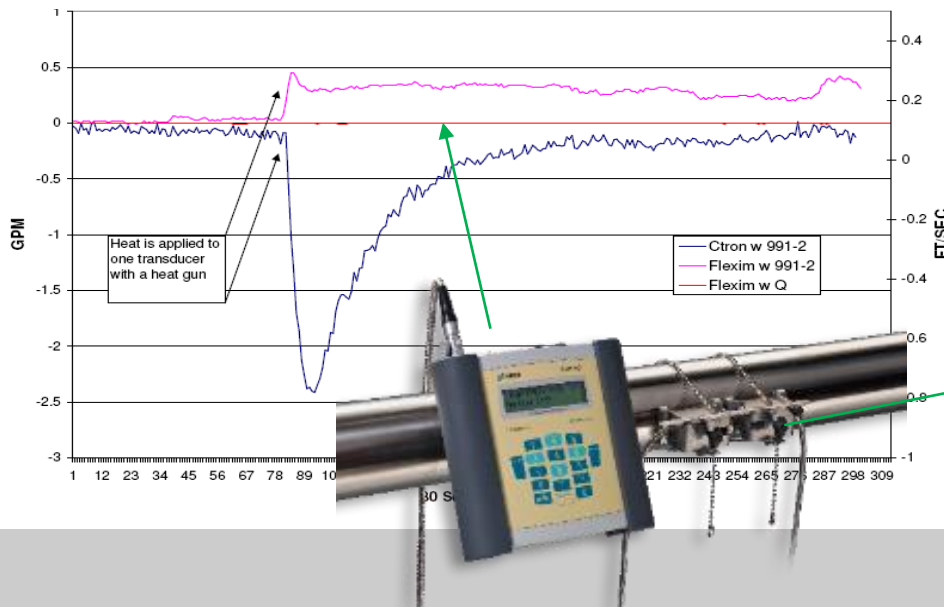
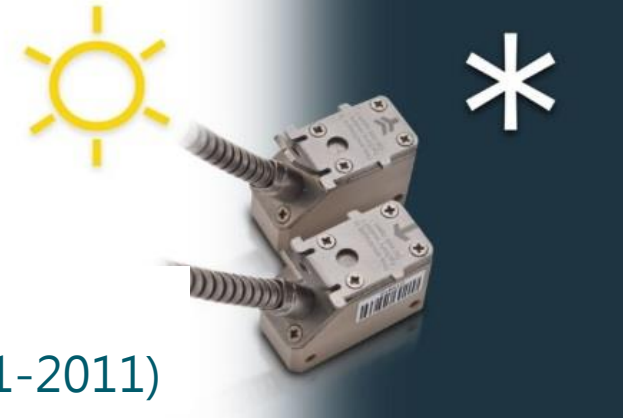



Figure 2.1b: Influence of temperature on the ultrasonic transducers for kerosene at 45 °C. (The meter was set up for Kerosene at 8 °C and a viscosity of 3 cSt). A shift in the error curve of approximately 2% is observed when the temperature compensation is disabled (OFF).

精準度



校正報告



校正日期: 2017 年 月 日
報告編號:
第 1 頁 共 4 頁

委託單位:
地 址:
儀器名稱: 超音波流量計
廠牌型號: **FLEXIM / G601(探頭型號:CDMINZ7)**
序 號:

上項儀器經本實驗室校正, 結果如附頁。
本報告含附頁共 肆 頁, 分離使用無效。
本報告未經本實驗室同意, 不得摘錄複製。
本校正報告僅對送校件結果負責。

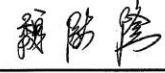

 實驗室主管

台塑石化股份有限公司
校正實驗室

地 址: 雲林縣麥寮鄉台塑工業園區1號
電 話: (05)6816287
傳 真: (05)6816288

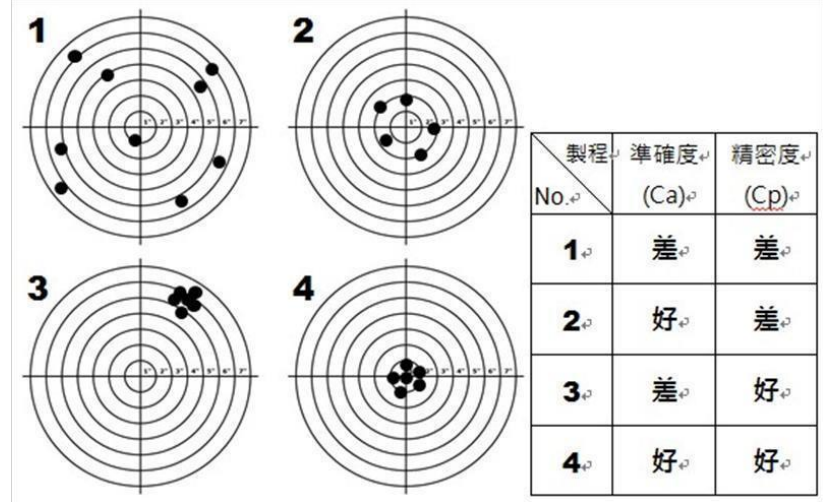

1

管內液體流量量測方法

2

流量計原理

3

流量計用途介紹

4

超音波流量計的操作使用

流量計應用

超音波 Ultrasonic

時間差-嵌入 都卜勒 科氏力 渦流 渦輪 流孔板 光學 熱質量
 Transit-Time Wetted Doppler Coriolis Vortex Turbine Orifice Optic Thermal Mass

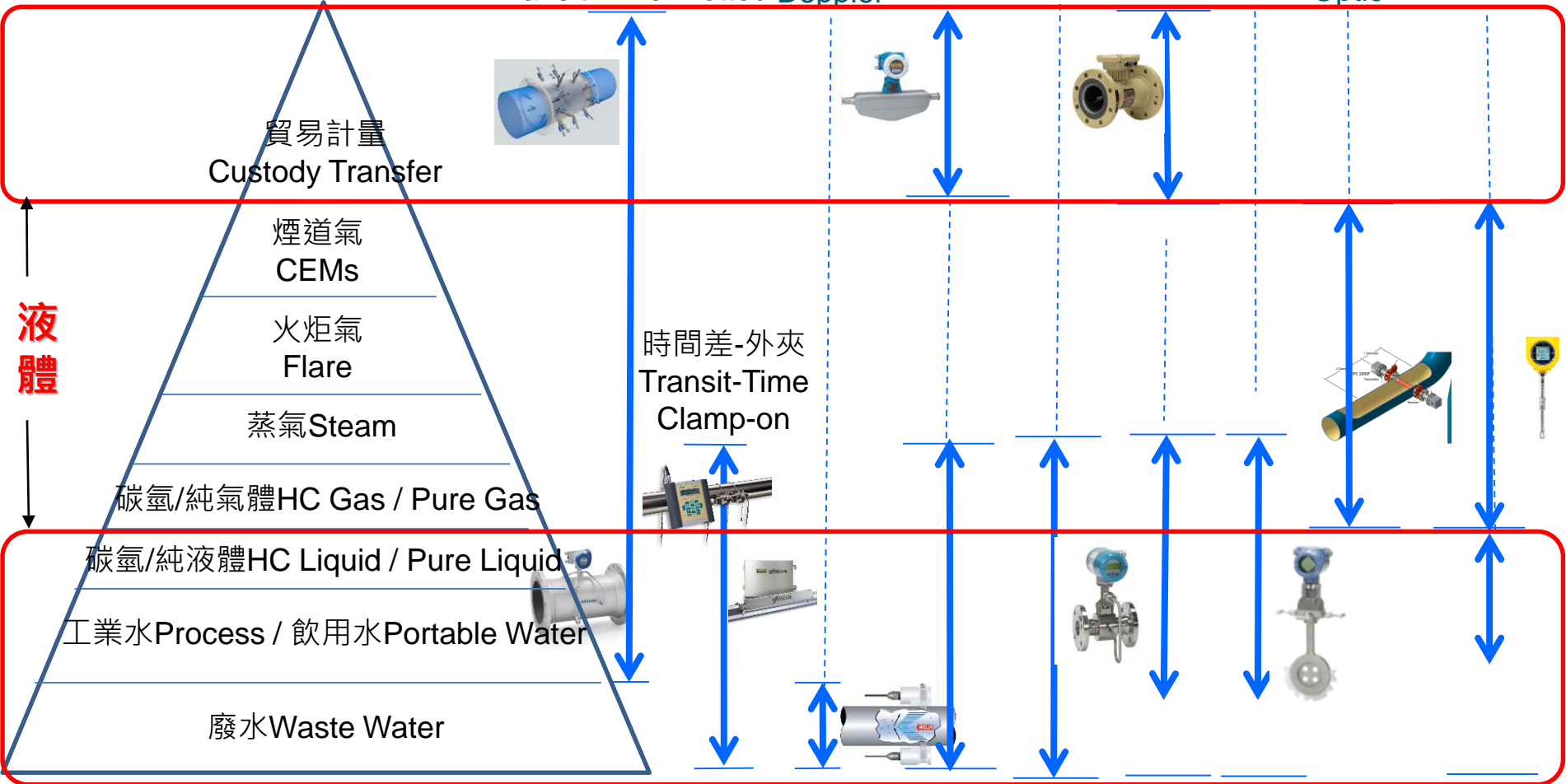



類型		超音波流量計		都普勒流量計	電磁式流量計	渦流式流量計	科氏力流量計	
安裝型式	短管一體式	✓		✓	✓	✓	✓	
	插入式	✓				✓		
	外夾式		✓	✓				
不受震動影響		✓	✓	✓	✓			
不接觸流體			✓	✓				
精準度-無直管要求							✓	
特殊材質要求		✓			✓	✓	✓	
量測量		體積流量		體積流量	體積流量	體積流量	質量流量/密度	
換算量		密度→質量流量 溫度→熱能(BTU)/(濃度)				密度→質量流量	體積流量	
適用流體	氣體	✓	✓			✓	✓	
	液體	✓	✓					
	液體	導電		✓	✓	✓	✓	✓
		不導電		✓	✓		✓	✓
		高粘度		✓		✓		✓
		固體物、氣泡	<10%	<10%	>10%	✓		✓
專門領域	腐蝕性流體 (煙道氣/ 火炬氣/蒸氣)	超純度/高毒性 遊校/節能/ (高廢液/污水/ 濃度)	高廢液/污水	高廢液/污水	蒸氣	貿易計量(\$) 濃度		

熱能源效能應用- 空調系統檢測 & 熱交換

空調系統檢測

➤ 冰水、冷卻水系統

1) 流量測定

2) 能量測定(含溫度)

溫度輸入符合能源計量規定 DIN EN1434-1

➤ 蒸汽鍋爐效能

1) 熱迴水流量

➤ 空壓機效能

1) 出口流量

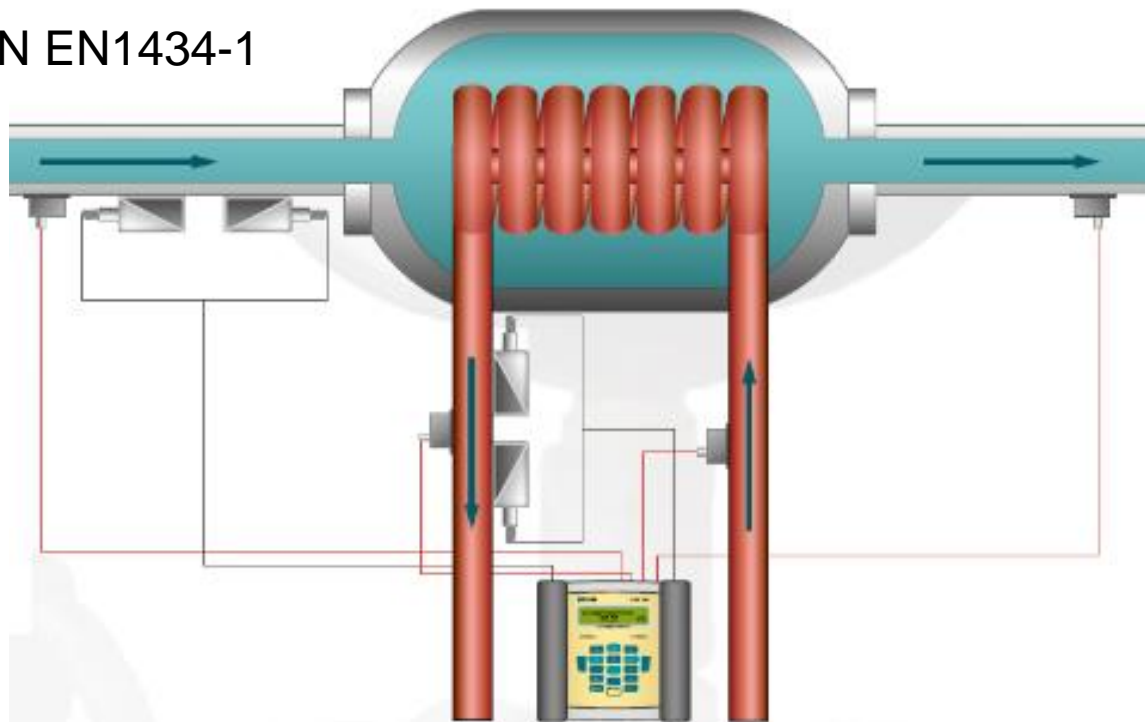

*Simultaneous heat quantity measurement on both circuits of a heat exchanger
(2 flow channels, 4 temperature inputs)*

流量檢測應用- 水(大型管)

飲用水



水系統-侷限位置



地下水泥管道



特大管道

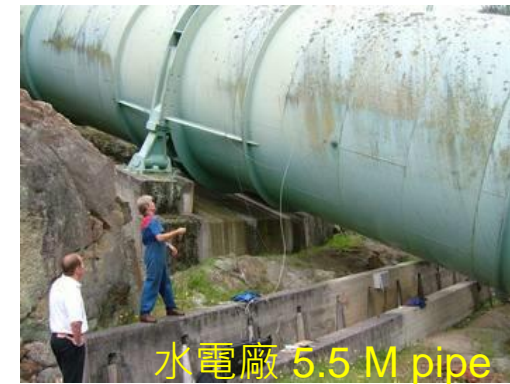

大型管道



應用- 泵控制和泵效能評估

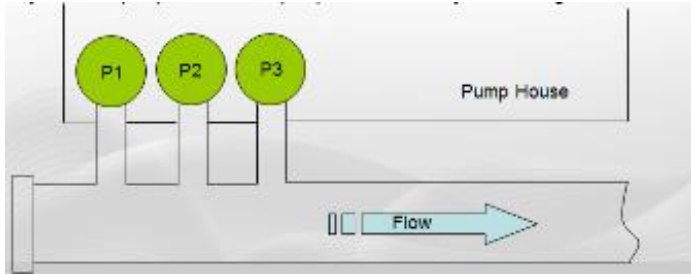

林口火力電廠 (海水泵, 1.2M pipe)

鋼鐵行業應用



連鑄冷卻水 3" CS pipe
(w/ scale CaF_2)



氨水 1" CS pipe



NG 6" CS pipe



潤滑油MR460
3" CS & SS pipe

流量檢測應用-廢水



污水抽水站



化學廢液(華邦)



酒廠廢液(金酒)



農村廢水排放
(使用引流管)

流量監測應用 & 抓漏



流量監測

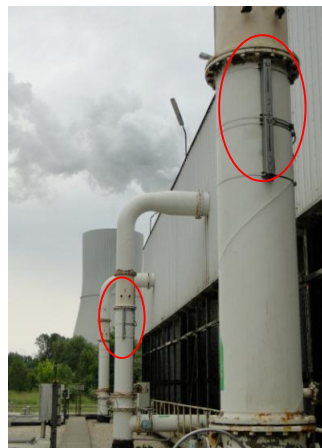

冷卻水系統



管線抓漏(金門水廠)

流量檢測應用- 超純水 / 小管徑

超純水 SS pipe / DN6

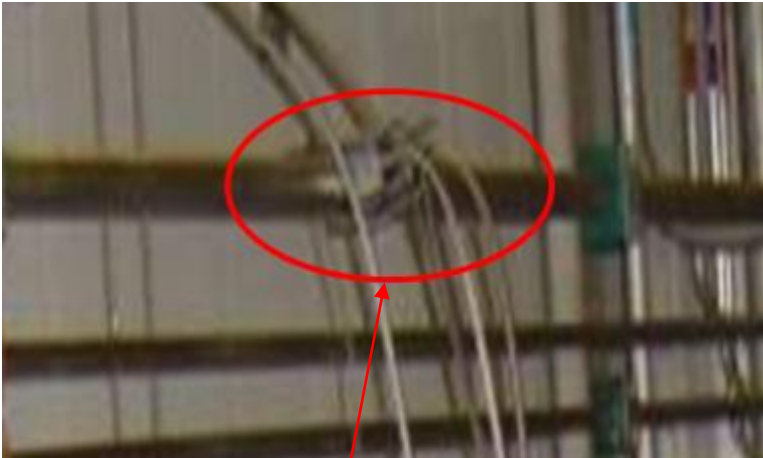

超純水 SS pipe / DN10 (生醫園區-喜康)



流量檢測應用- 極限溫度 (須搭配超高 / 超低溫導波配件)

超低溫

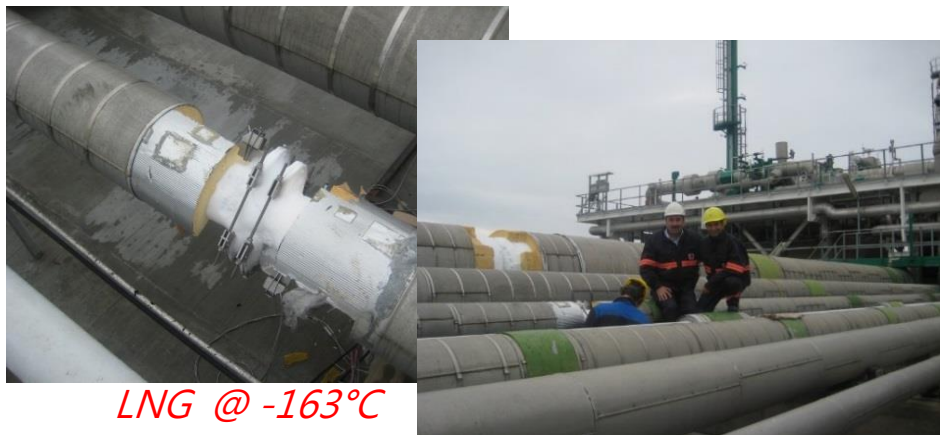

LNG @ -163°C



LO₂ @ -183°C
LN₂ @ -196°C

超高溫

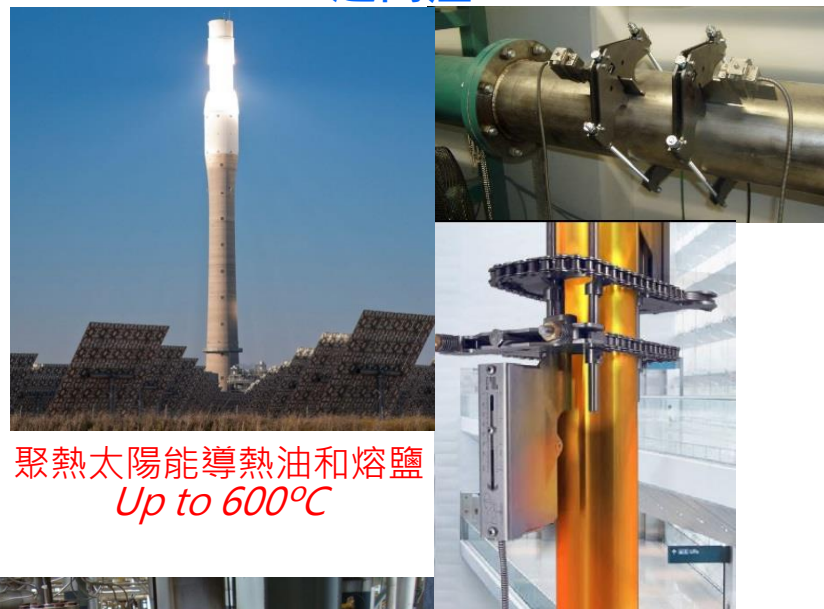

聚熱太陽能導熱油和熔鹽
Up to 600°C



煉油高溫製程 350°C

流量檢測應特殊應用- 高壓/ 超厚管 / 高固體含量

高壓厚管

超高壓厚管

水煤漿



固體70% / 219*17mm

石灰水



採煤 (高壓水) 壓力 300 – 400 Bar

LDPE, 2150 Bar(g), OD 90 mm, WT 26 mm



固體50% / DN700/橡膠內襯



250 Bar



特殊應用-有毒/侵蝕性介質流量和濃度測量(須選用濃度功能)

硫酸流量和濃度測量

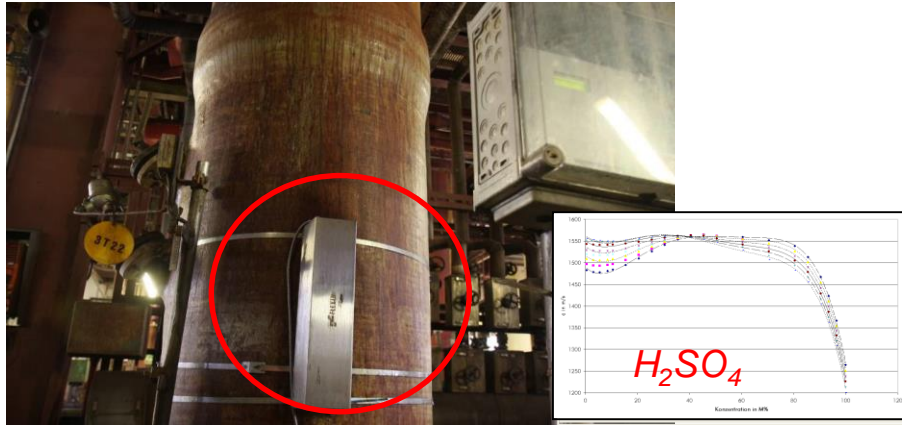

鹽水流量和濃度測量

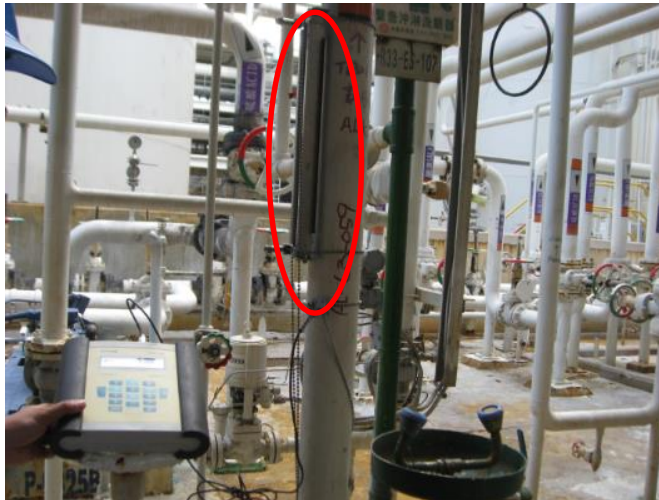
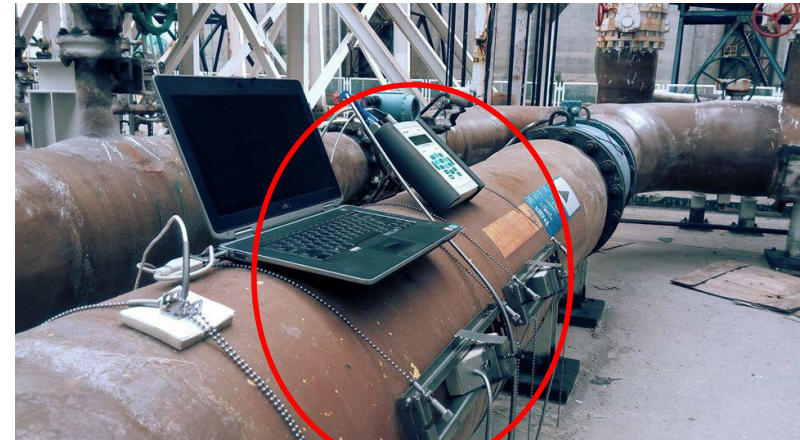

化肥、化工行業硫酸96-99%

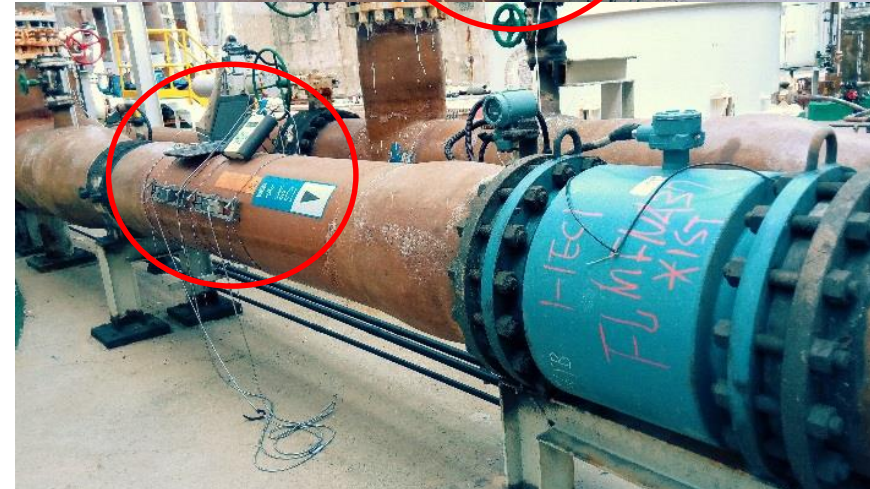

NaCl 26% 20" GRP pipe

1

管內液體流量量測方法

2

流量計原理

3

流量計用途介紹

4

超音波流量計的操作使用

審查流體條件

選合適安裝點

選擇安裝探頭

規劃參數

安裝夾具/探頭

測量

快速選擇安裝位置

supply line: $l \geq 10 D$

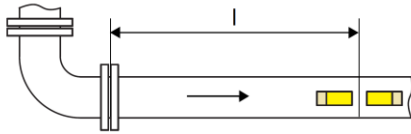

return line: $l \geq 5 D$

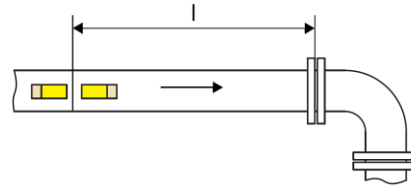

前10D/後5D的直管段位置 (一般情況下)
前2/3, 後1/3的直管段位置
(在直管段不能滿足前10D/後5D要求時)

- 水平管中有氣泡與沉澱
- 水平管垂直安裝 (12點/6點)
- 水平管側面安裝
 - A) 單聲道 (9點/3點)
 - B) 雙聲道 (8點/2點, 10點/3點)

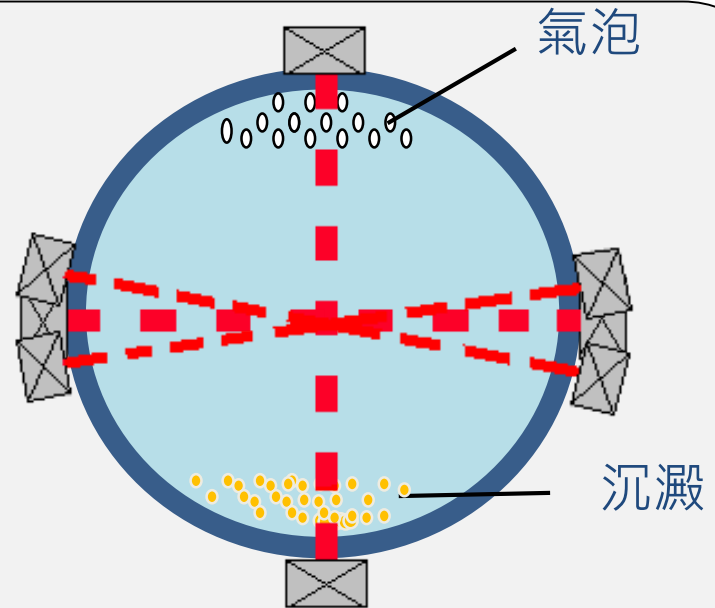
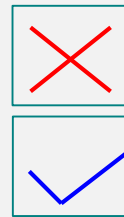

審查流體條件

選合適安裝點

選擇安裝探頭

規劃參數

安裝夾具/探頭

測量

水平管路

測量點選擇使感測器應安裝在管路的側面，讓發射的音波在管中水平傳播。因此位置在管道頂部聚集的**氣泡**或管底部的**固體沉積物**不會影響信號的傳輸

正確 

不利位置



垂直管路

測量點選擇在管道中介質向上流動的位置，管路必須被液體完全充滿

正確 

不利位置

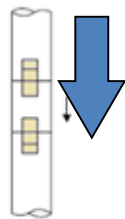
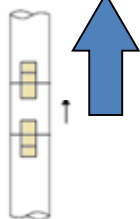

目的: 測量位置要飽管

液體流量建議探頭安裝位置 (安裝點應避開“不利位置”)

自由進、出口的管段

- 測量點選擇飽管位置，避免可能不保管位置

正確 

不利位置

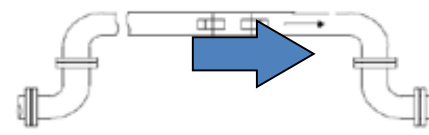

正確 

不利位置

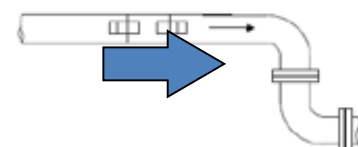
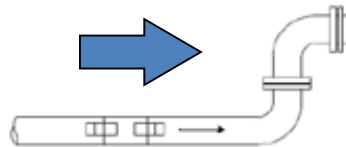

注意：液體流量量測時管道不應有氣泡或沉積物，即使是無氣泡的液體也可能在減壓後的位置上形成氣囊（膨脹），例如特別是在泵浦後方或擴管後的位置。

審查流體條件

選合適安裝點

選擇安裝探頭

規劃參數

安裝夾具/探頭

測量

測量點相對干擾源的建議距離 (D =測量點處的公稱管徑, L =推薦的距離)

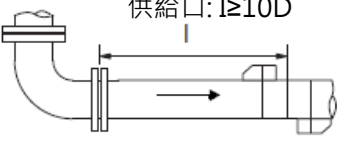
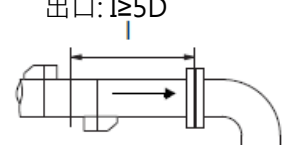
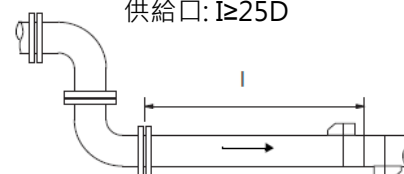
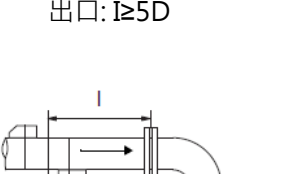
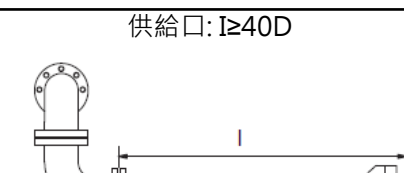
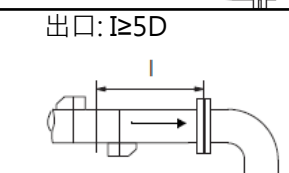
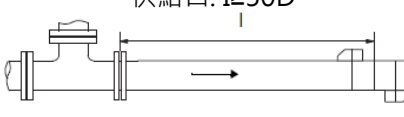
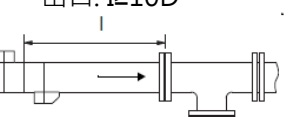
干擾源： 90°彎頭	供給口: $L \geq 10D$ 	出口: $L \geq 5D$ 
干擾源： 2X90°彎頭 同平面	供給口: $L \geq 25D$ 	出口: $L \geq 5D$ 
干擾源： 2X90°彎頭 不同平面	供給口: $L \geq 40D$ 	出口: $L \geq 5D$ 
干擾源： T型接頭	供給口: $L \geq 50D$ 	出口: $L \geq 10D$ 

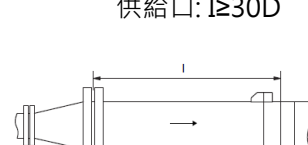
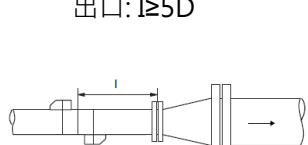
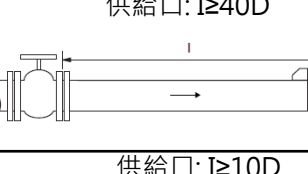
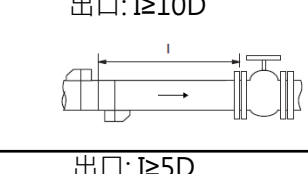
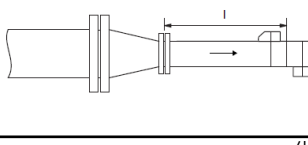
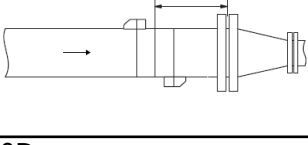
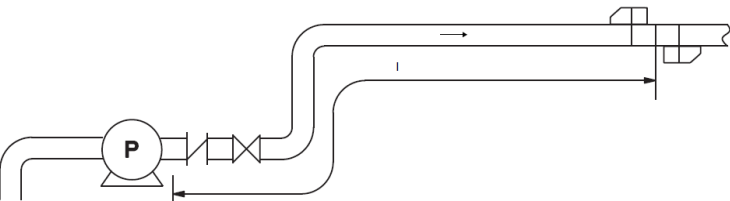
干擾源： 擴張接頭	供給口: $L \geq 30D$ 	出口: $L \geq 5D$ 
干擾源： 閥門	供給口: $L \geq 40D$ 	出口: $L \geq 10D$ 
干擾源： 縮小接頭	供給口: $L \geq 10D$ 	出口: $L \geq 5D$ 
干擾源： 泵(壓縮機)	供給口: $L \geq 50D$ 	

- 避免把測量點選在管道變形、有缺陷以或焊縫的位置附近
- 確認使用的探頭適用於測量點的溫度條件

審查流體條件

選合適安裝點

選擇安裝探頭

規劃參數

安裝夾具/探頭

測量

選擇探頭的安裝配置 (一對探頭)

依測量範圍和測量條件來選擇測量配置

對角式配置

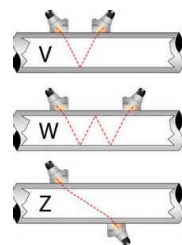
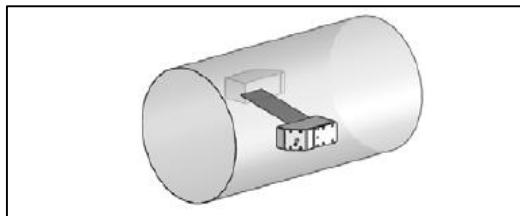

反射式配置

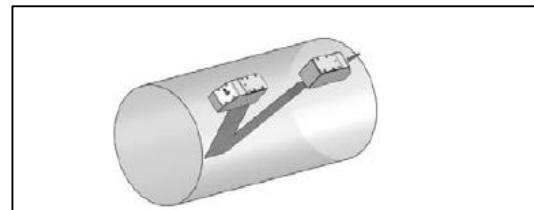

聲程數少

- 聲波訊號衰減少 (訊號強度: 聲程 1>2>3...)
 - 適合**強烈衰減介質**或**內管壁存在沉積物**
- 流速對音波偏移度影響小
 - 可測流速範圍大; 也適合聲速變化大的介質

聲程數多

- 平均不同方向的測量值能補償**橫向流動**的影響 (音束由多個聲程的方向穿過管道)
 - 適合直管段不足位置
- 聲程數 $\uparrow \rightarrow \sum \Delta t \uparrow$, 平均數 $\uparrow \rightarrow$ **測量精度 \uparrow**
 - 適合**小管徑低流速**應用

當探頭正常工作時

當夾角 θ 變小時

當夾角 θ 變大時

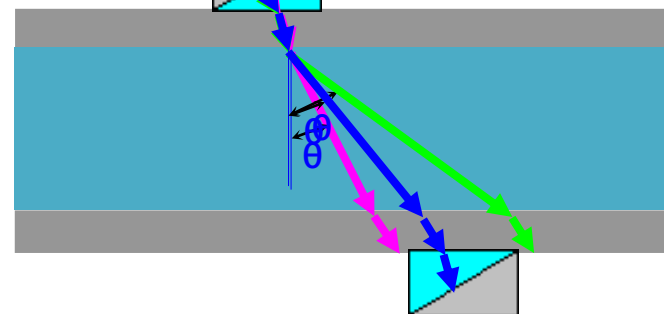

審查流體條件

選合適安裝點

選擇安裝探頭

規劃參數

安裝夾具/探頭

測量

計算探頭安裝“距離”

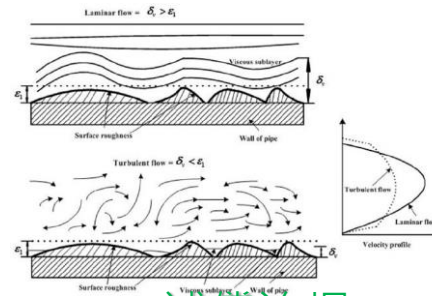
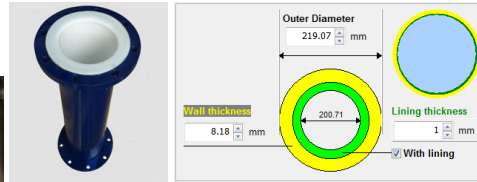
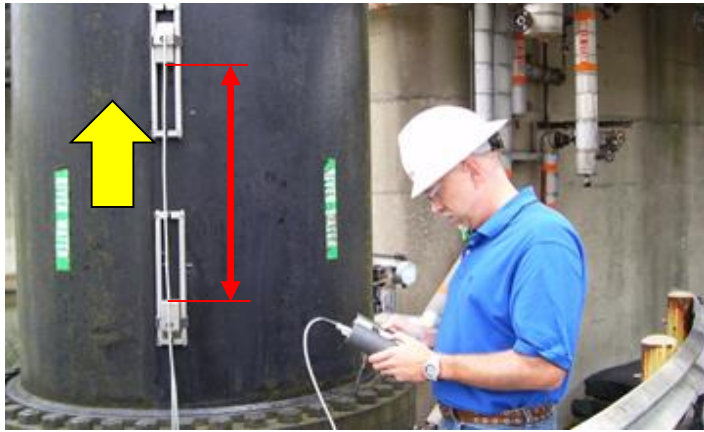

補償流場

$$Q = V * A \text{ (內截面積)}$$

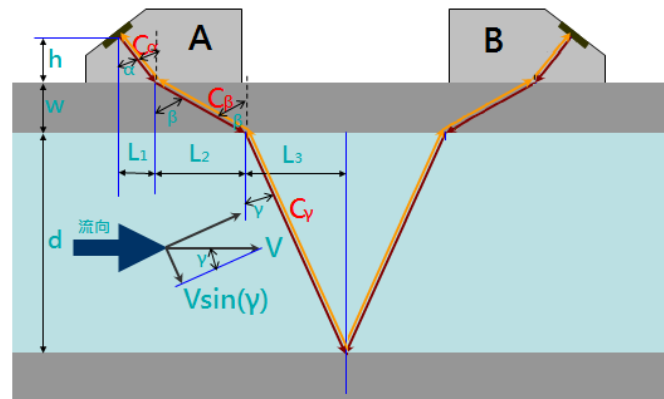

管道參數

1. 管外徑
2. 管壁厚
3. 管材
4. (內襯: 厚度/ 材質)
5. 管內壁粗造度

流體參數

6. 流體
7. 流體溫度
8. 流體壓力 (氣體)

審查流體條件

選合適安裝點

選擇安裝探頭

規劃參數

安裝夾具/探頭

測量

F601 STD 基本安裝配置

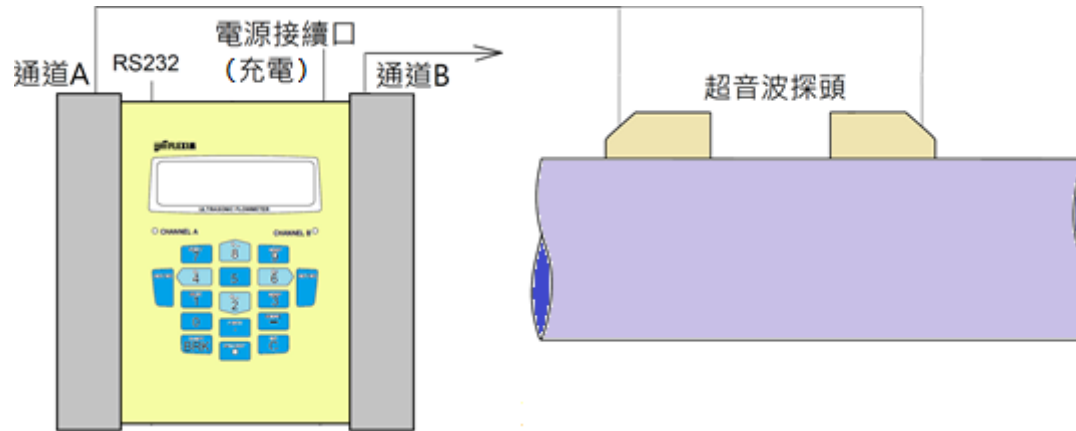

探頭安裝聲程數的選擇與距離

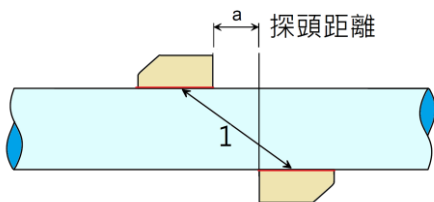

對角線式(反側)安裝, 聲程數1

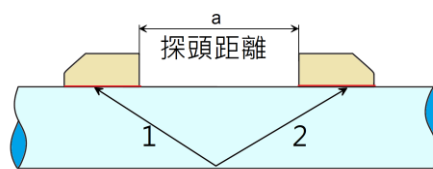

反射式(同側)安裝, 聲程數2

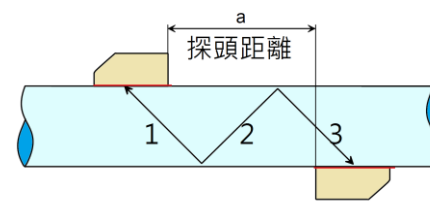

對角線式(反側)安裝, 聲程數3

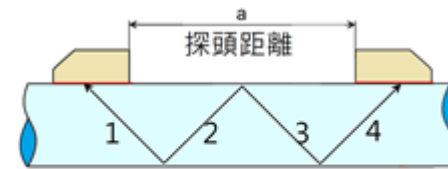

反射式(同側)安裝, 聲程數4

審查流體條件

選合適安裝點

選擇安裝探頭

規劃參數

安裝夾具/探頭

測量

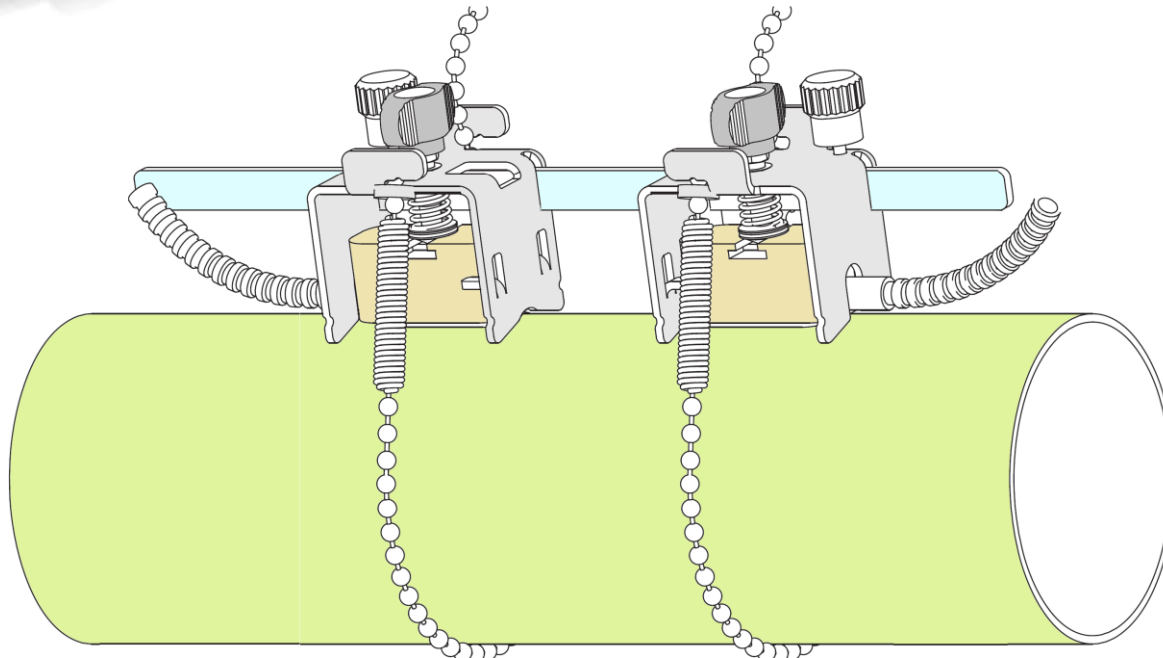

審查流體條件

選合適安裝點

選擇安裝探頭

規劃參數

安裝夾具/探頭

測量

測量中可能遇到的問題

*** 打開存檔功能，記錄一段時間，以連線軟體下載檔案進行診斷



Q&A

Thank you

超音波流量計問題請諮詢:

- 綠色生產力基金會
- 綠基會指定專家 (or 德國弗萊克森mwang@flexim.com)